

Instrukcja obsługi

AR200

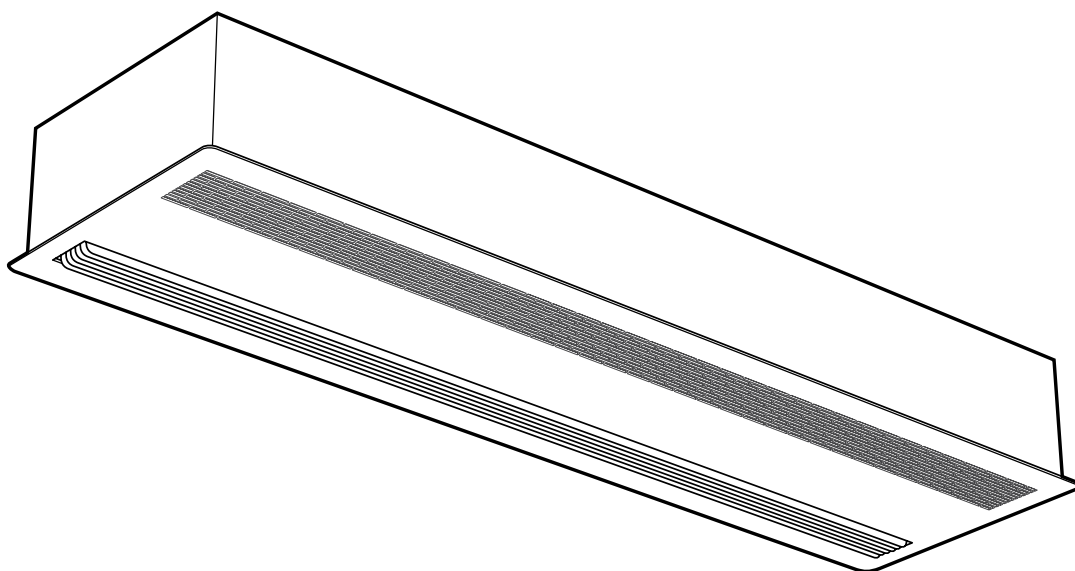

Wymiary

AR210/AR215

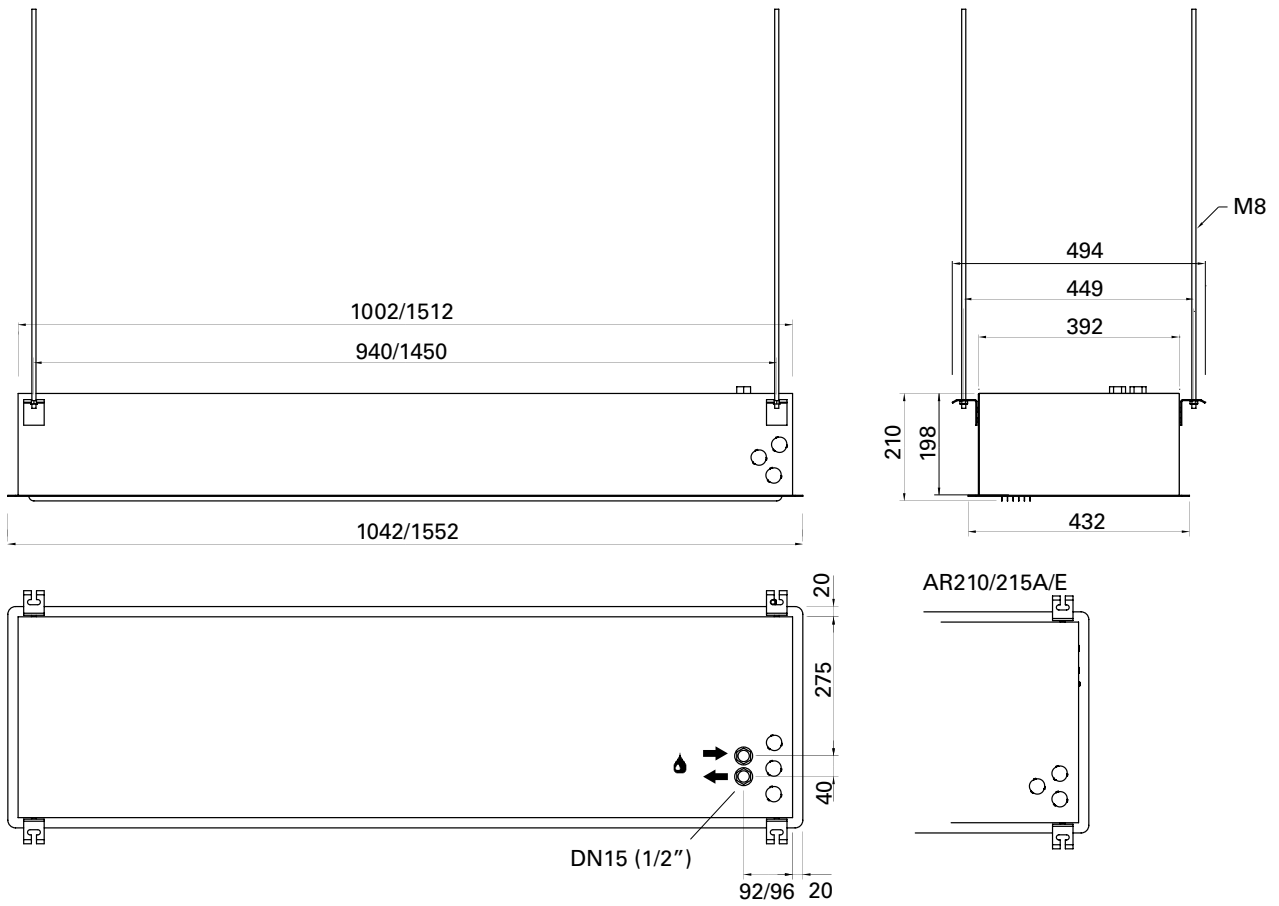

AR220

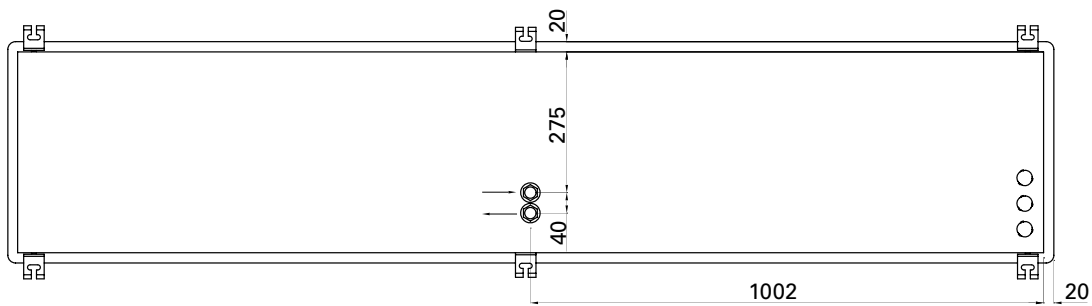
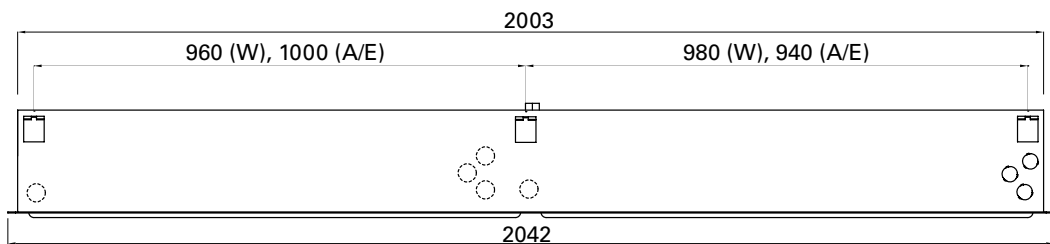

AR220A/E

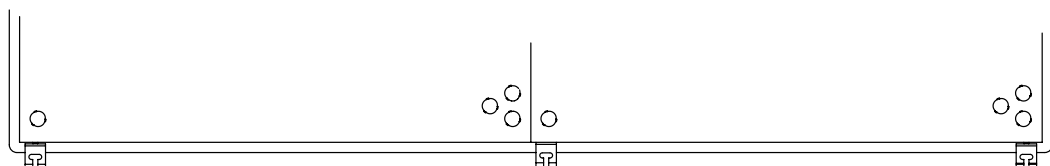

Montaż

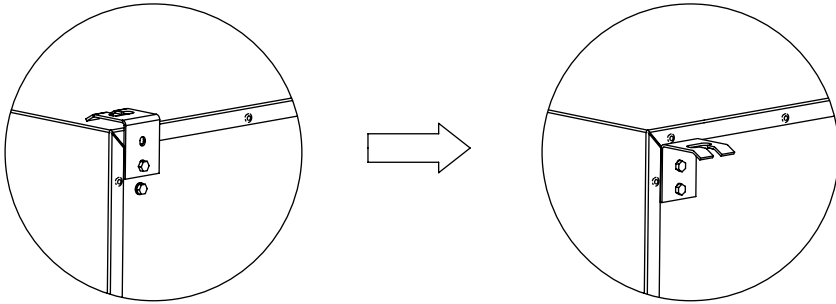

Rys. 1. Uchwyty mocujące w pozycji transportowej.

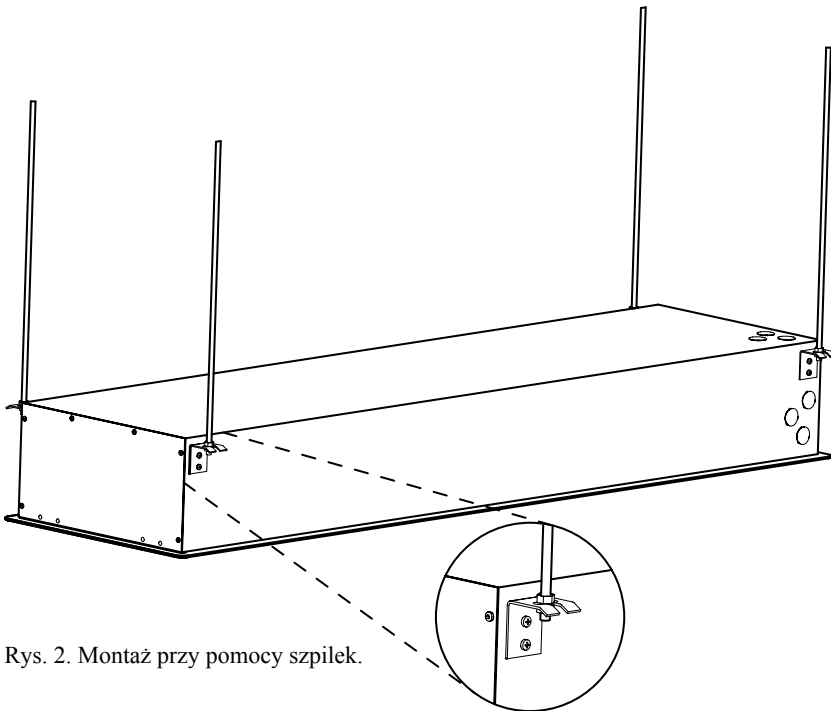

Rys. 2. Montaż przy pomocy szpilek.

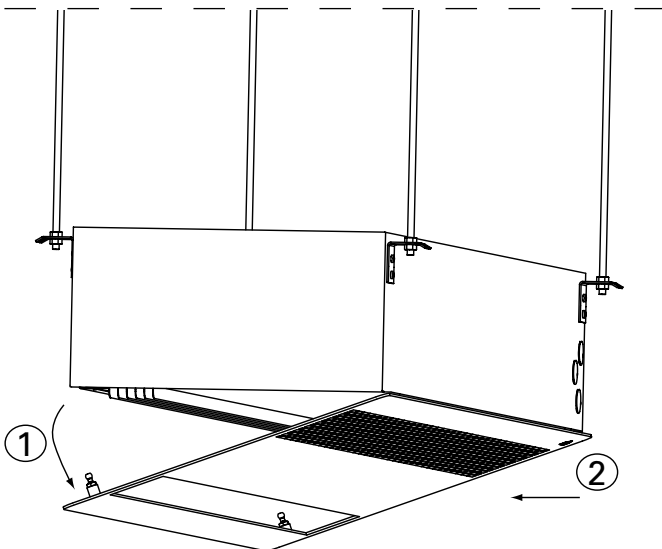

Rys. 3. Demontaż dolnej pokrywy.

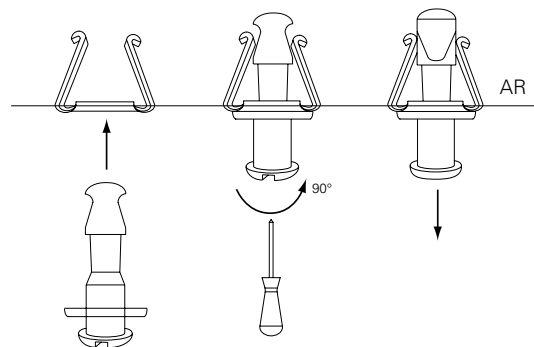

Rys. 4. Funkcje mocowania na zatrzask

Montaż

Minimalne odległości

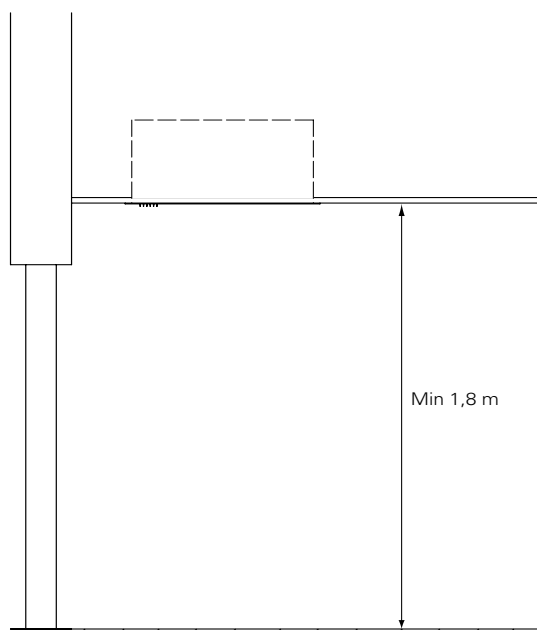

Rys. 5 Minimalna odległość od podłogi AR200E.

Akcesoria

Sterowanie

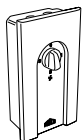

CB30N

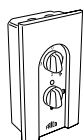

CB32N

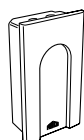

RTI2

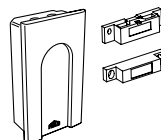

MDC



T10S

CB30N	AR200A/W, IP44
CB32N	AR200E, IP44
RTI2	IP44
MDC	IP44
T10S	IP30

Akcesoria

Sterowanie wodne 

VRS20/25

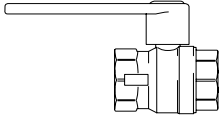

AV20/25

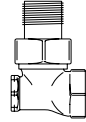

BPV10

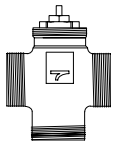

TRVS20/25

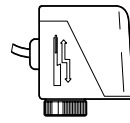

SD20

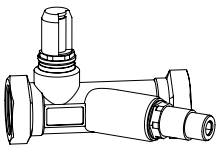

JVF20/25

Akcesoria

Type	RSK-nr [SE]
VRS20	673 17 99
VRS25	673 18 00
TVVS20	673 92 96
TVVS25	673 92 97
SD20	672 70 37

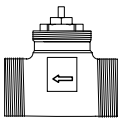

TVVS20/25

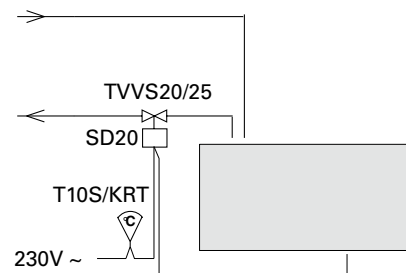
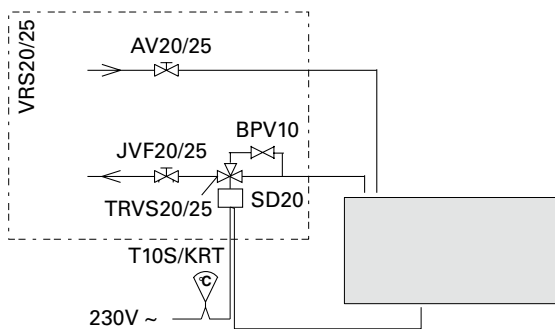

Schemat połączeń AR200A

Schemat połączeń wewnętrznych
Opcje sterowania urządzeń bez ogrzewania

Poziom 1

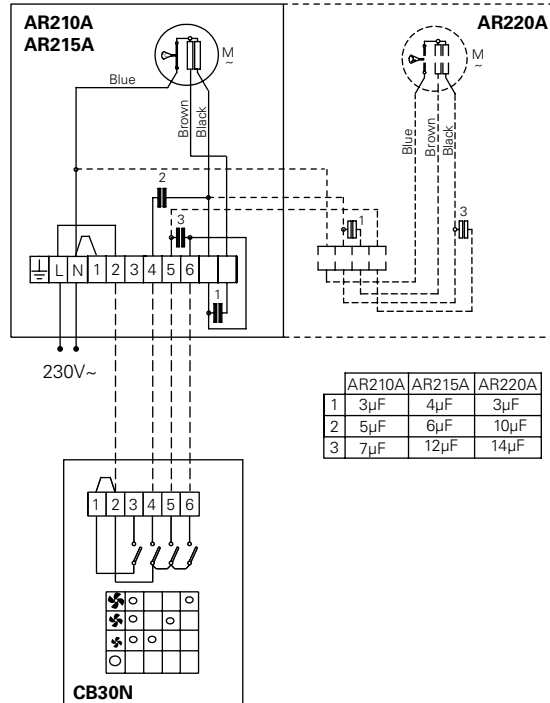

Poziom 2

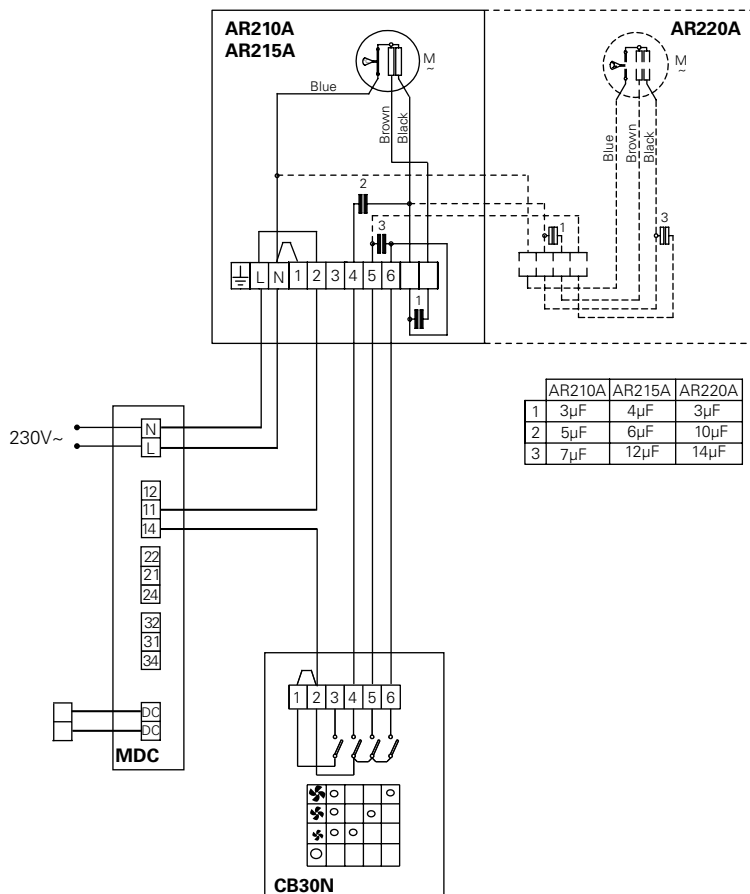

Schemat połączeń AR200E

Płytki podłączeniowej

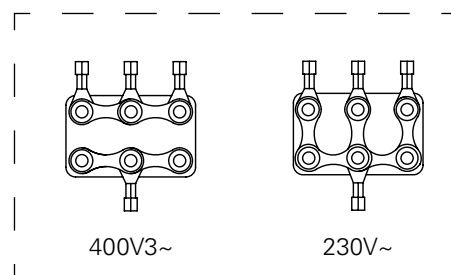
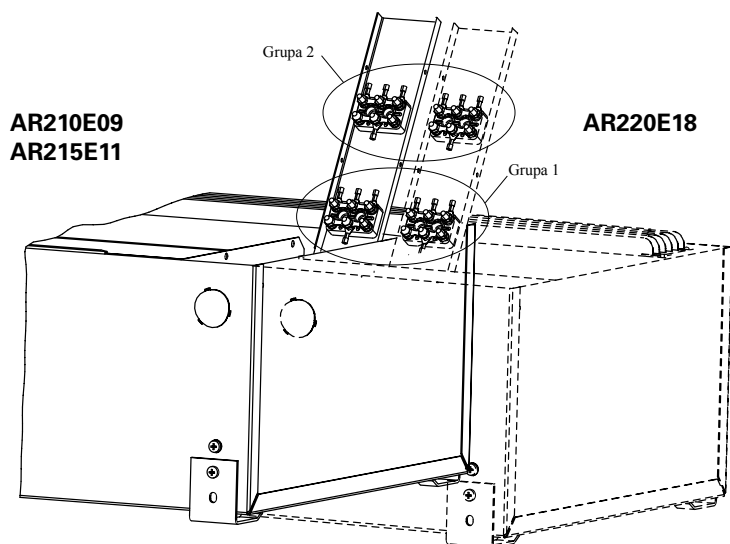

Schemat połączeń AR200E

Wewnętrzny

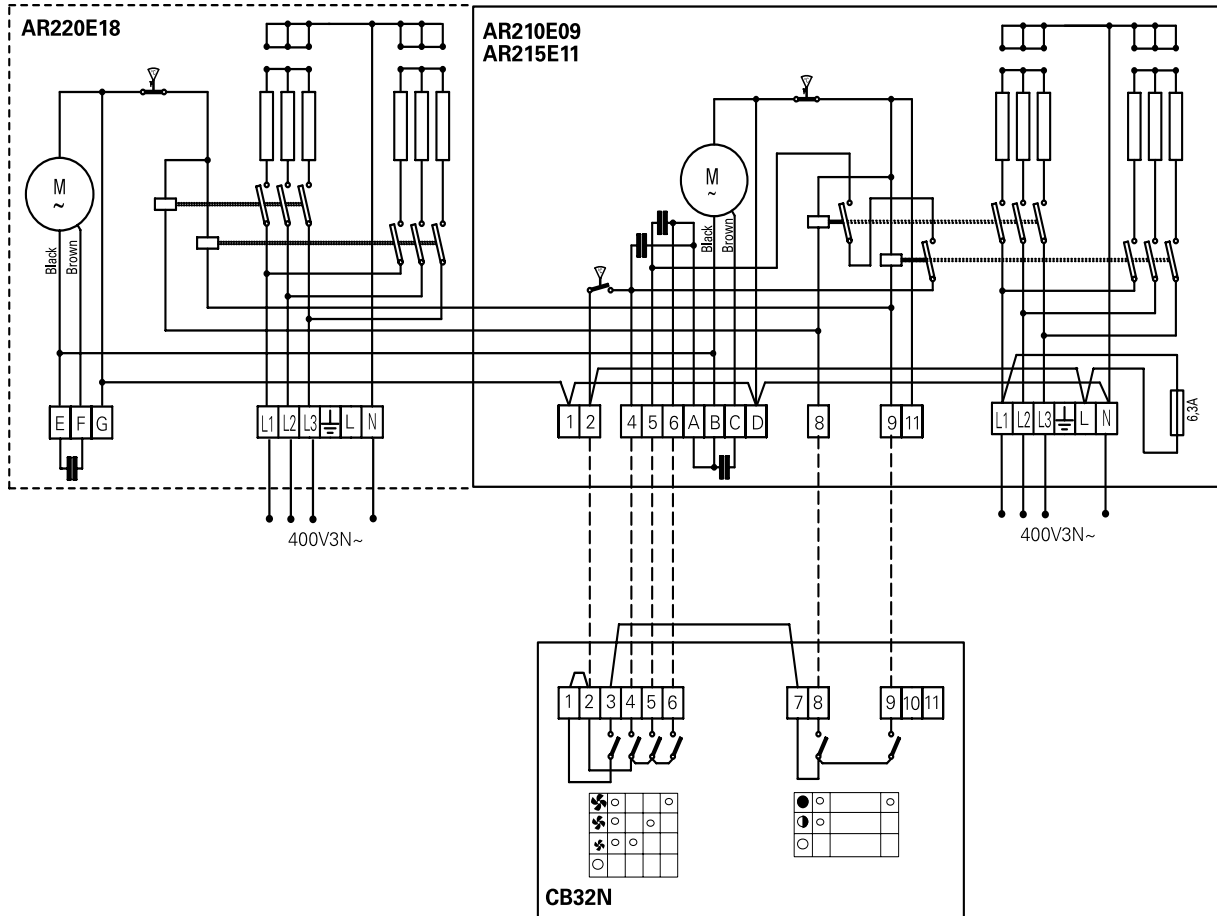

Główny - podrzędny

Uwaga! Wyjmij bezpiecznik wewnętrzny jednostki podporządkowanej.

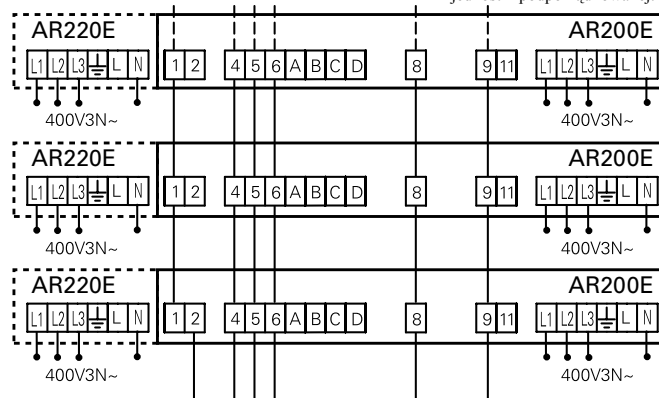

AR200

Uwaga! Możliwości wyboru zasilania i stopnia mocy grzewczej ograniczane obowiązującymi przepisami elektrycznymi

AR210E09

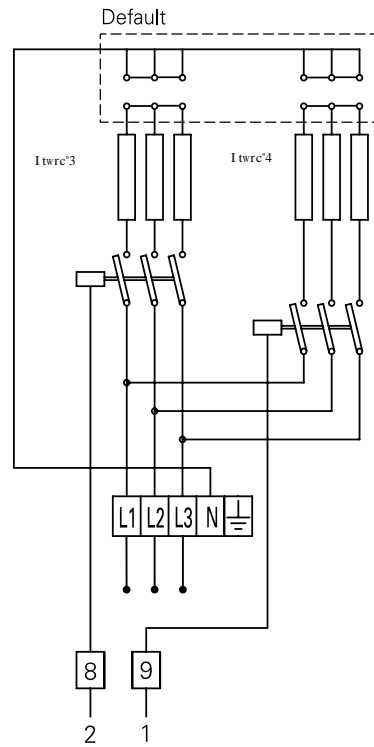
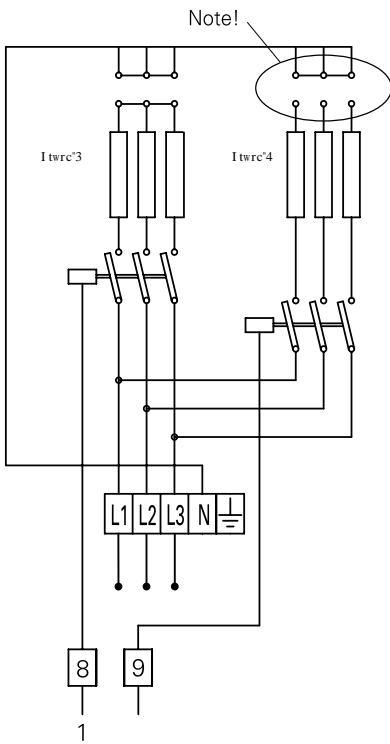

622X5ϕ

U_{vqrkg} "3<""5mY"" I twrc"3<"5z3222 Y

U_{vqrkg} "4<""////"" I twrc"4<"5z4222 Y

622X5ϕ

U_{vqrkg} "3<""8mY"" I twrc"3<"5z3222 Y

U_{vqrkg} "4<"";mY"" I twrc"4<"5z4222 Y

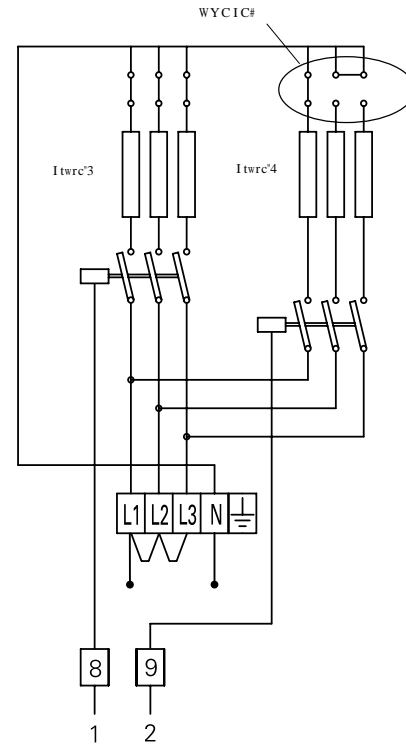
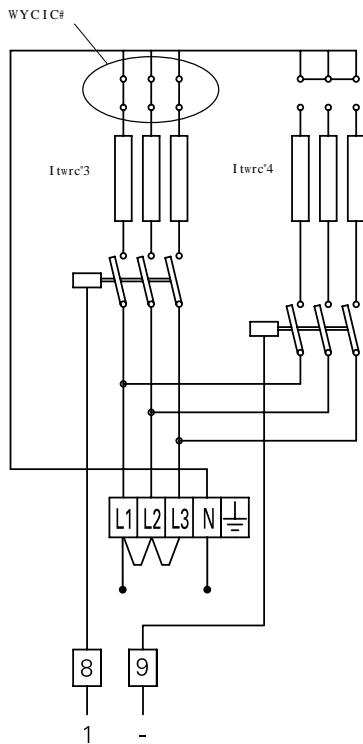

452X5ϕ

U_{vqrkg} "3< kW

W
W

kW
kW

W
W

AR200

To choose output - connect the contactors as outlined in the wiring diagrams below.

AR215E11

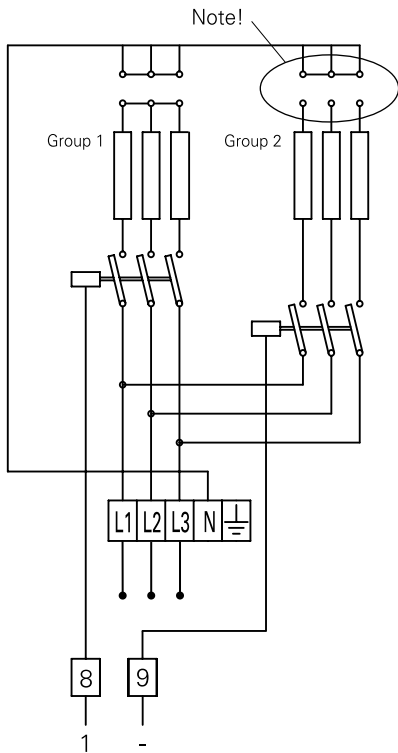

400V3~
 Step 1: 4,5kW Group 1: 3x1500W
 Step 2: ---- Group 2: 3x2250W

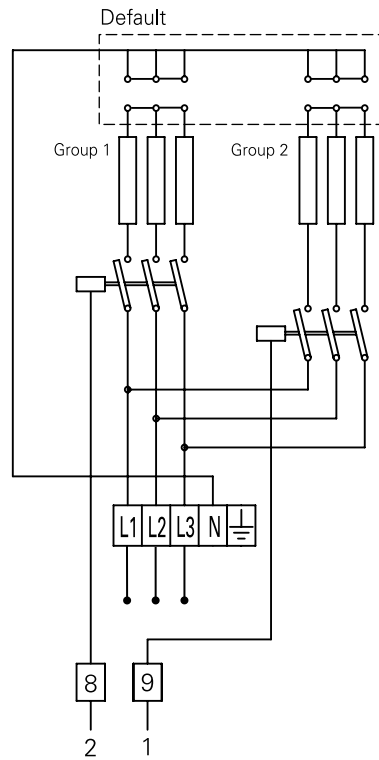

400V3~
 Step 1: 6,8kW Group 1: 3x1500W
 Step 2: 11,3kW Group 2: 3x2250W

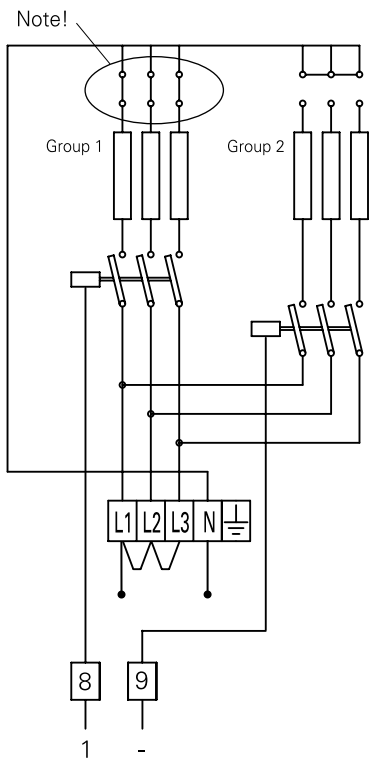

230V~
 Step 1: 4,5kW Group 1: 3x1500W
 Step 2: ---- Group 2: 3x2250W

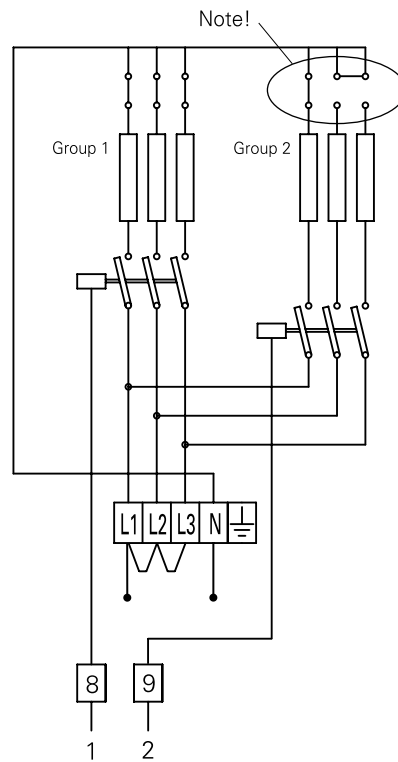

230V~
 Step 1: 4,5kW Group 1: 3x1500W
 Step 2: 6,8kW Group 2: 3x2250W

AR200

To choose output - connect the contactors as outlined in the wiring diagrams below.

AR220E18

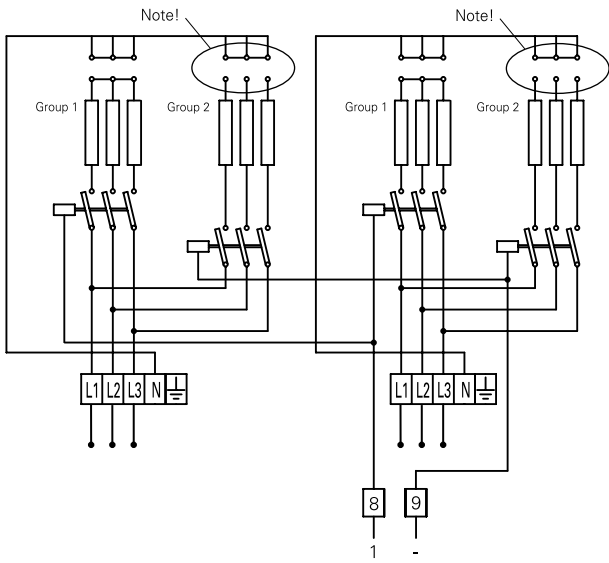

400V3~
 Step 1: 2x3kW Group 1: 3x1000W
 Step 2: ---- Group 2: 3x2000W

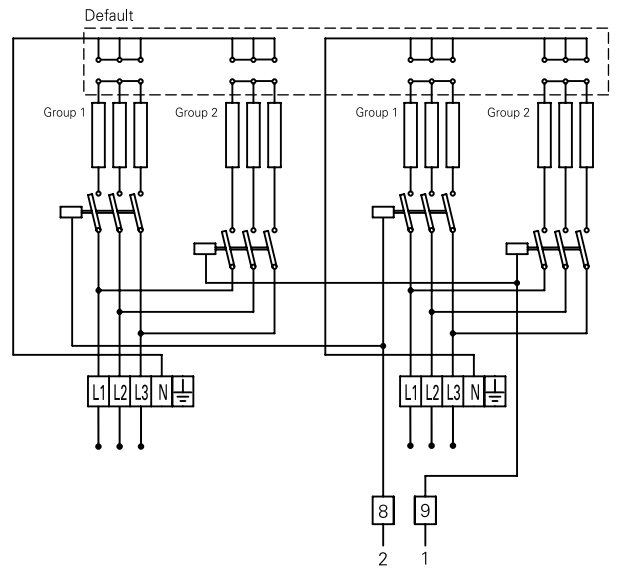

400V3~
 Step 1: 2x6kW Group 1: 3x1000W
 Step 2: 2x9kW Group 2: 3x2000W

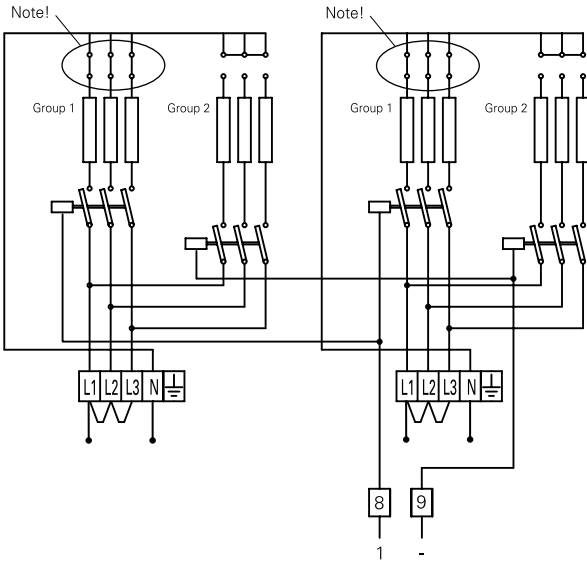

230V~
 Step 1: 2x3kW Group 1: 3x1000W
 Step 2: ---- Group 2: 3x2000W

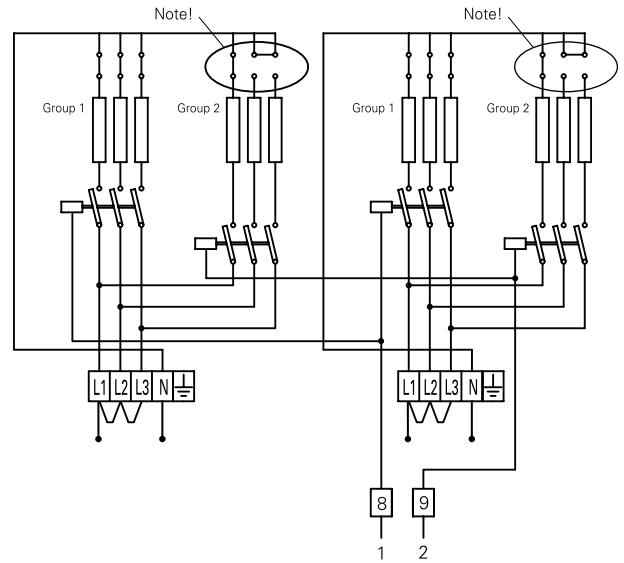

230V~
 Step 1: 2x3kW Group 1: 3x1000W
 Step 2: 2x5kW Group 2: 3x2000W

Wiring diagrams AR200 E

Level 1

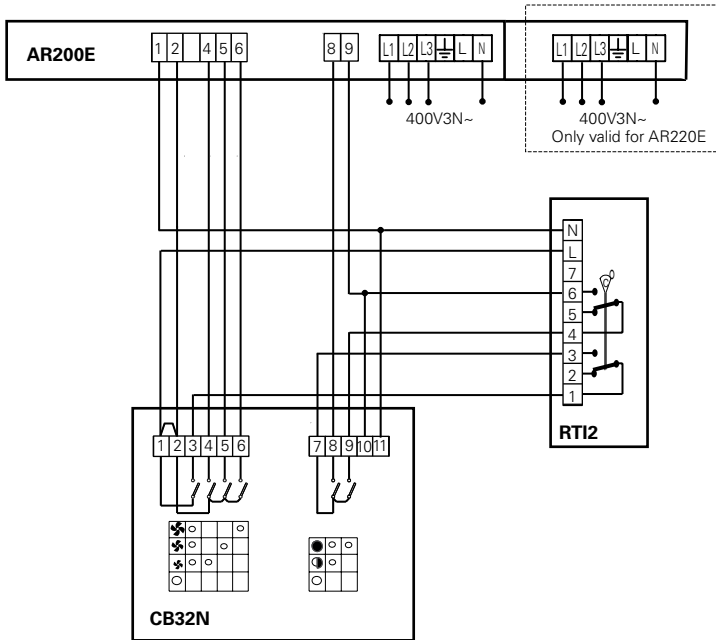

Level 2

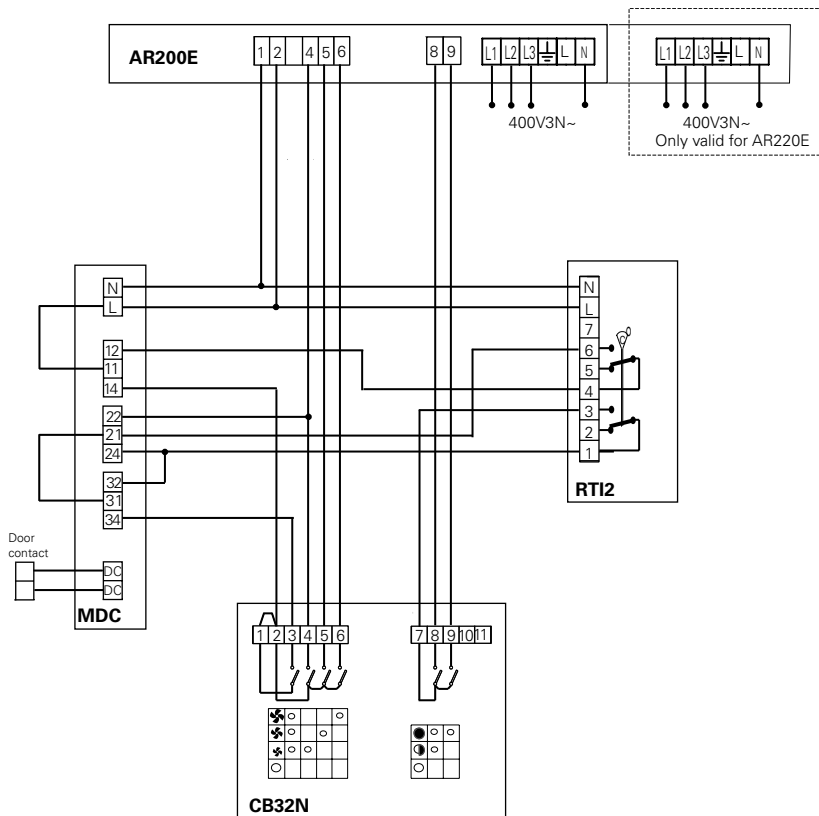

Wiring diagrams AR200 W

Level 1

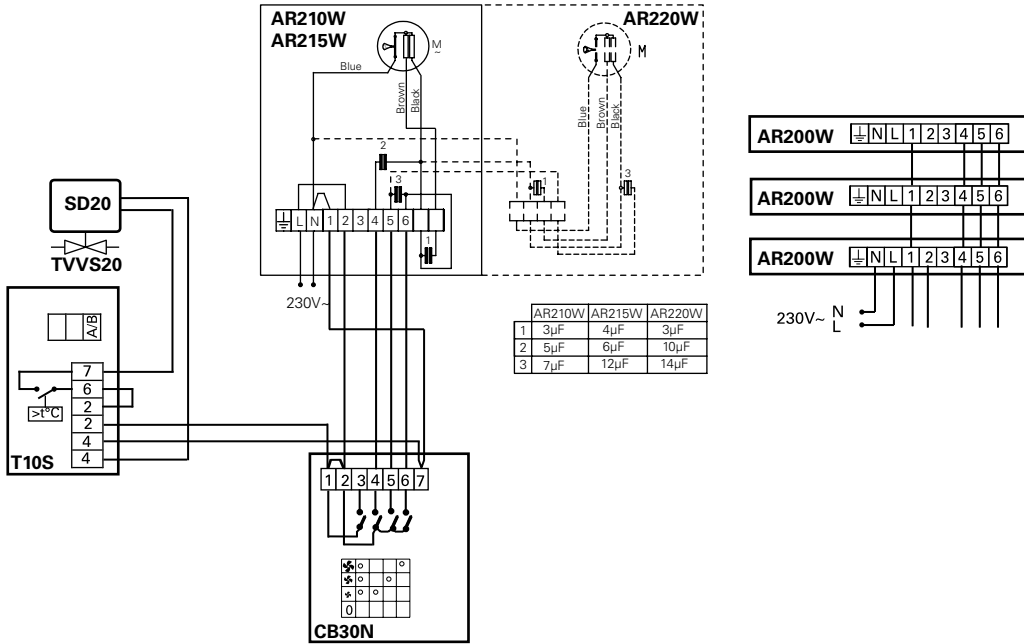

Level 2

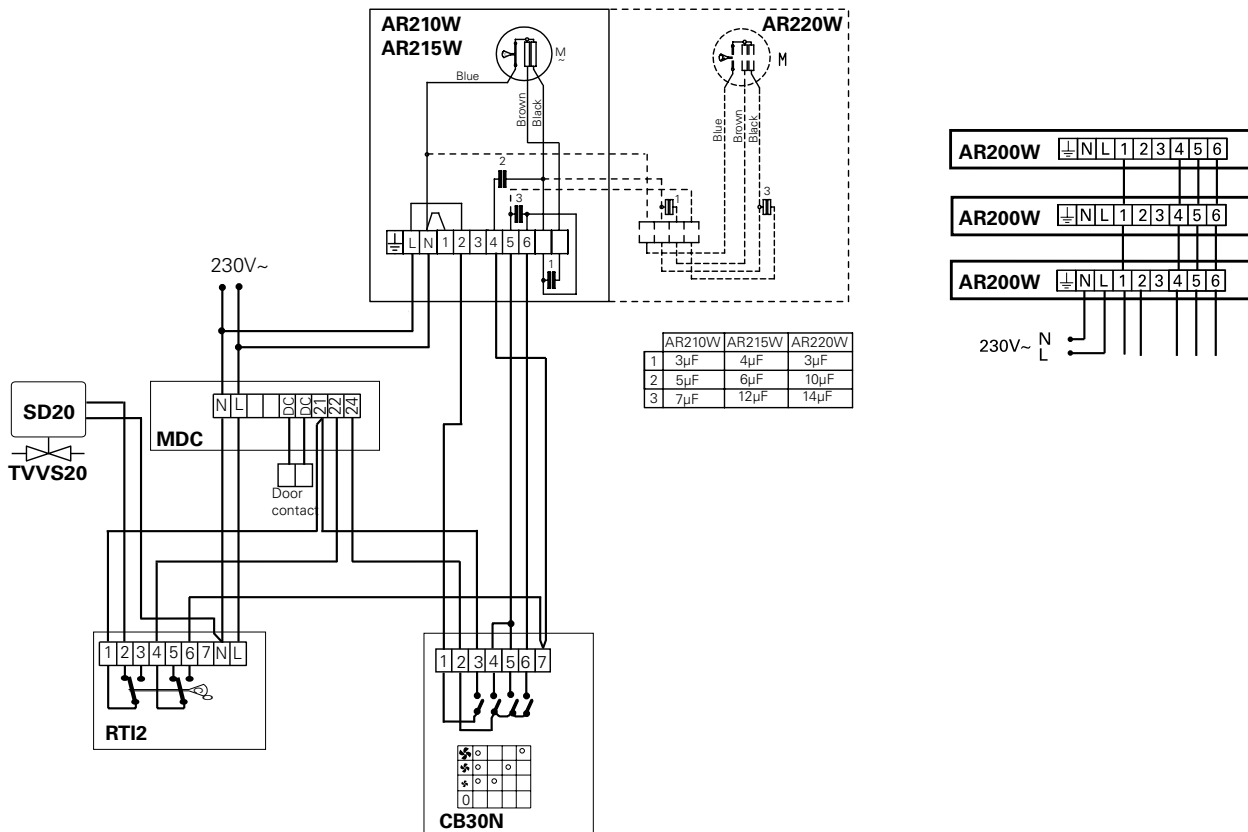

Output charts water AR200

AR200W

			Supply water temperature: 110 °C Room temperature: +18 °C Outlet air temperature: +35 °C*1				Water temperature: 110/80 °C Room temperature: +18 °C			
Type	Fan position	Airflow [m ³ /h]	Output [kW]	Return water temp. [°C]	Water flow [l/s]	Pressure drop [kPa]	Output *2 [kW]	Outlet air temp. [°C]	Water flow [l/s]	Pressure drop [kPa]
AR210W	max	1000	5,8	44,1	0,02	1,6	9,8	46,9	0,08	15,6
	min	700	4,0	38,7	0,01	0,7	7,9	51,3	0,06	10,5
AR215W	max	1600	9,2	45,8	0,04	0,9	15,6	46,8	0,13	8,3
	min	1000	5,8	39,6	0,02	0,3	11,7	52,5	0,10	5,0
AR220W	max	2000	11,5	44,3	0,04	1,4	19,5	46,7	0,16	14,2
	min	1400	8,1	39,0	0,03	0,7	15,7	51,0	0,13	9,6

			Supply water temperature: 90 °C Room temperature: +18 °C Outlet air temperature: +35 °C*1				Water temperature: 90/70 °C Room temperature: +18 °C			
Type	Fan position	Airflow [m ³ /h]	Output [kW]	Return water temp. [°C]	Water flow [l/s]	Pressure drop [kPa]	Output *2 [kW]	Outlet air temp. [°C]	Water flow [l/s]	Pressure drop [kPa]
AR210W	max	1000	5,8	49,4	0,03	3,7	8,0	41,5	0,10	23,0
	min	700	4,0	43,1	0,02	1,6	6,4	45,0	0,08	15,5
AR215W	max	1600	9,2	50,5	0,06	2,1	12,7	41,4	0,16	12,3
	min	1000	5,8	43,1	0,03	0,7	9,5	46,1	0,12	7,3
AR220W	max	2000	11,5	49,7	0,07	3,4	15,8	41,3	0,19	20,3
	min	1400	8,1	43,4	0,04	1,4	12,7	44,8	0,16	14

			Supply water temperature: 80 °C Room temperature: +18 °C Outlet air temperature: +35 °C*1				Water temperature: 80/60 °C Room temperature: +18 °C			
Type	Fan position	Airflow [m ³ /h]	Output [kW]	Return water temp. [°C]	Water flow [l/s]	Pressure drop [kPa]	Output *2 [kW]	Outlet air temp. [°C]	Water flow [l/s]	Pressure drop [kPa]
AR210W	max	1000	5,8	52,6	0,05	7,6	6,6	37,3	0,08	16,5
	min	700	4,0	45,8	0,03	2,7	5,3	40,2	0,06	11,1
AR215W	max	1600	9,2	53,3	0,08	4,2	10,4	37,2	0,13	8,7
	min	1000	5,8	45,3	0,04	1,2	7,0	41,0	0,10	5,2
AR220W	max	2000	11,5	52,9	0,10	7,0	13	37,2	0,16	15
	min	1400	8,1	46,1	0,06	2,5	10,4	40,0	0,13	10,1

			Supply water temperature: 70 °C Room temperature: +18 °C Outlet air temperature: +35 °C*1				Water temperature: 70/50 °C Room temperature: +18 °C			
Type	Fan position	Airflow [m ³ /h]	Output [kW]	Return water temp. [°C]	Water flow [l/s]	Pressure drop [kPa]	Output *2 [kW]	Outlet air temp. [°C]	Water flow [l/s]	Pressure drop [kPa]
AR210W	max	1000	5,8	56,3	0,10	26,5	5,1	33,1	0,06	10,9
	min	700	4,0	49,0	0,05	6,5	4,1	35,4	0,05	7,4
AR215W	max	1600	9,2	56,4	0,17	14,3	8,1	32,9	0,10	5,7
	min	1000	5,8	47,8	0,06	2,6	6,1	35,9	0,07	3,4
AR220W	max	2000	11,5	56,5	0,21	24,9	10,2	33,0	0,12	9,9
	min	1400	8,1	49,4	0,10	6,2	8,2	35,2	0,10	6,7

*1) Recommended outlet air temperature for good comfort and optimized output.

*2) Nominal output at given supply and return water temperature.

See www.frico.se for additional calculations.

Output charts water AR200

AR200 W

			Supply water temperature: 60 °C Room temperature: +18 °C Outlet air temperature: +35 °C*1				Water temperature: 60/40 °C Room temperature: +18 °C			
Type	Fan position	Airflow [m ³ /h]	Output [kW]	Return water temp. [°C]	Water flow [l/s]	Pressure drop [kPa]	Output *2 [kW]	Outlet air temp. [°C]	Water flow [l/s]	Pressure drop [kPa]
AR210W	max	1000	–	–	–	–	3,7	28,8	0,04	6,3
	min	700	4,0	52,6	0,01	43,9	3,0	30,5	0,04	4,3
AR215W	max	1600	–	–	–	–	5,8	28,6	0,07	3,2
	min	1000	5,8	50,8	0,15	12,8	4,3	30,7	0,05	1,9
AR220W	max	2000	–	–	–	–	7,3	28,8	0,09	5,7
	min	1400	8,1	53,0	0,28	43,5	5,9	30,4	0,07	3,8

			Supply water temperature: 55 °C Room temperature: +18 °C Outlet air temperature: +35 °C*1				Water temperature: 55/35 °C Room temperature: +18 °C			
Type	Fan position	Airflow [m ³ /h]	Output [kW]	Return water temp. [°C]	Water flow [l/s]	Pressure drop [kPa]	Output *2 [kW]	Outlet air temp. [°C]	Water flow [l/s]	Pressure drop [kPa]
AR210W	max	1000	–	–	–	–	2,9	26,7	0,04	4,3
	min	700	–	–	–	–	2,4	28,0	0,03	2,9
AR215W	max	1600	–	–	–	–	4,5	26,4	0,05	2,2
	min	1000	–	–	–	–	3,4	28,0	0,04	1,3
AR220W	max	2000	–	–	–	–	5,8	26,6	0,07	3,9
	min	1400	–	–	–	–	4,7	27,9	0,06	2,6

– = at the current water temperatures and airflows, the air outlet temperature will be less than 35 °C.

*1) Recommended outlet air temperature for good comfort and optimized output.

*2) Nominal output at given supply and return water temperature.

See www.frico.se for additional calculations.

AR200

Technical specifications | AR200 A without heat ✨

Type	Output	Airflow	Sound level*1	Voltage	Amperage	Length	Weight
	[kW]	[m ³ /h]	[dB(A)]	[V]	[A]	[mm]	[kg]
AR210A	0	650/1200	34/50	230V~	0,5	1042	18
AR215A	0	950/1750	34/50	230V~	0,6	1552	25
AR220A	0	1300/2400	40/54	230V~	1,0	2042	36

Technical specifications | AR200 E electrically heated ⚡

Type	Output steps 400V3N~	Output steps 230V~	Airflow	Sound level*1	Δt*2	Voltage	Amperage 400V3N~	Amperage 230V~	Length	Weight
	[kW]	[kW]	[m ³ /h]	[dB(A)]	[°C]	[V]	[A]	[A]	[mm]	[kg]
AR210E09	3	-	650/1200	34/50	13/7	400V3N~	4,3	-	1042	23
	6/9	-	650/1200	34/50	41/22	400V3N~	13	-	1042	23
	-	3	650/1200	34/50	13/7	230V~	-	13	1042	23
	-	3/5	650/1200	34/50	23/12	230V~	-	22	1042	23
AR215E11	4,5	-	950/1750	34/50	14/8	400V3N~	6,5	-	1552	32
	6,8/11,3	-	950/1750	34/50	35/20	400V3N~	16	-	1552	32
	-	4,5	950/1750	34/50	14/8	230V~	-	20	1552	32
	-	4,5/6,8	950/1750	34/50	21/12	230V~	-	30	1552	32
AR220E18	6	-	1300/2400	40/54	13/7	400V3N~	8,7	-	2042	44
	12/18	-	1300/2400	40/54	41/22	400V3N~	26	-	2042	44
	-	6	1300/2400	40/54	13/7	230V~	-	26	2042	44
	-	6/10	1300/2400	40/54	23/12	230V~	-	43	2042	44

Technical specifications | AR200 W water heated 💧

Type	Output*3	Airflow	Sound level*1	Δt*2,3	Watervolume	Voltage	Amperage	Length	Weight
	[kW]	[m ³ /h]	[dB(A)]	[°C]	[l]	[V]	[A]	[mm]	[kg]
AR210W	6,6	700/1000	41/49	24/21	0,5	230V~	0,4	1042	21
AR215W	10,4	1000/1600	37/50	24/20	0,9	230V~	0,6	1552	39
AR220W	13,0	1400/2000	44/53	23/20	1,1	230V~	1,0	2042	42

*1) Conditions: Distance to the unit 5 metres. Directional factor: 2. Equivalent absorption area: 200 m². At lowest/highest airflow.

*2) Δt = temperature rise of passing air at maximum heat output and lowest/highest airflow.

*3) Applicable at water temperature 80/60 °C, air temperature, in +18 °C.

AR200E is delivered as 9 kW, 11 kW and 18 kW (400V3N~) models, but they are convertible to 230V~ and different outputs as shown in above table.

Protection class AR200A/E/W: normal design (IP20).

CE compliant.

Assembly and operating instructions

General Instructions

Read these instructions carefully before installation and use. Keep this manual for future reference.

The guarantee is only valid if the units are used in the manner intended by the manufacturer and in accordance with the Frico mounting and operating instructions.

Application area

AR200 is especially suited for environments with high demands in respect of design. It is recessed in ceilings above entry doors and other small doors where the height is no greater than 2,5 metres. A low height makes it possible to install AR200 where ceiling space is limited. The recessed installation and low sound level makes AR200 very discreet.

Protection class: IP20

Operation

Air is drawn in from underneath and blown out downwards towards the entrance so that it shields the door opening and minimises heat loss. To get the best curtain effect, the unit must extend the full width of the door opening.

The grille for directing exhaust air is adjustable and is normally angled outwards to achieve the best protection against incoming cold air. The air speed is adjusted to the desired airflow.

The efficiency of the air curtain depends on the air temperature, pressure differences across the doorway and any wind pressure.

NOTE! Negative pressure in the building considerably reduces the efficiency of the air curtain. The ventilation should therefore be balanced!

Installation

AR200 unit is installed horizontally with the supply air grille facing downwards as close to the door as possible, concealed in the false ceiling. The only visible part of the unit is the underside that is level with the ceiling.

For the protection of wider doorways, several units can be mounted next to each other.

Ensure that the base plate is accessible and can be fully opened.

The minimum distance from the outflow to the floor is 1800 mm (see fig. 5).

1. The mounting brackets (x 4, x 6 on the 2 metre units) are fixed to the unit during transport. Loosen these, turn them around and screw into place on the unit according to figure 1 on p.3.
2. Hang up on threaded bars (M8) according to figure 2 on p.3 (not included).
3. Adjust the height using the upper nut so that the frame is level with the ceiling. Lock using the lower nut.

Electrical installation

The installation, which should be preceded by an omnipolar switch with a contact separation of at least 3 mm, should only be wired by a competent electrician and in accordance with the latest edition of IEE wiring regulations.

1. The base plate/service hatch is opened by loosening the snap fixings located on the down side (turn 90°) and then loosening the base plate from the rim. See fig. 3 and 4.
2. AR200A: The connection to the unit's side or top is made with 2x1,5 mm² + earth.
AR200E: The connection to the unit's

cont. on next page

side or top is made using a five-core cable with an earth wire. The largest cable diameter for the terminal block is 16 mm².

AR200W: The control cable is connected via knock outs to the unit's side or top, with 2x1.5 mm² + earth.

The cable glands used must meet the protection class requirements.

3. Close the base plate/service hatch and make sure that the snap fixings lock properly.

See wiring diagrams.

AR200E:
The units can be switched between different outputs and for 230V~/400V3~. The connection box is located on the right side of the unit, viewed from inside the room. The switching block is on the left side. On the 2 metre unit, the two switching blocks are located in the middle and the connection spaces are on the outside. The 2-metre unit requires dual power supplies.

Type	Output [kW]	Voltage [V]	Minimum area [mm ²]
AR210E09	3	400V3N~	1.5
	6	400V3N~	1.5
	9	400V3N~	2.5
	3	230V~	2.5
	5	230V~	6
AR215E11	4.5	400V3N~	1.5
	6.8	400V3N~	1.5
	11.3	400V3N~	4
	4.5	230V~	4
	6.8	230V~	10
AR220E18	6(2x3)	400V3N~	1.5
	12(2x6)	400V3N~	1.5
	18(2x9)	400V3N~	2.5
	6(2x3)	230V~	2.5
	10(2x5)	230V~	6

Start-up (E)

When the unit is used for the first time or after a long period of disuse, smoke or odour may result from dust or dirt that has collected on the element. This is completely normal and disappears after a short time.

Connecting the water coil (W)

The installation must be carried out by an authorised installer.

The water coil has copper tubes with aluminium fins and is suitable for connection to a closed water heating system. The heating coil must not be connected to a mains pressure water system or an open water system.

Note that the unit shall be preceded by a regulating valve, see for instance Frico valve kit.

Connections (DN15 (1/2")), inside thread) to the water heating coil are located on the top of the unit to the right (seen from inside the building). For AR220W the water connection is located in the middle of the top side of the unit.

A vent valve should be connected at a high point in the pipe system. Air- and draining valves are not included in the heating coil.

The connections to the heating coil must be equipped with shut off valves to allow problem free removal.

NOTE: Care must be taken when connecting the pipes. Use a wrench or similar to hold the air-curtain connections to prevent straining of the pipes and subsequent water leakage during connection to water supply pipe-work.

Adjustment of the air curtain and air flow

The direction and speed of the air flow should be adjusted considering the load on the opening. Pressure forces affect

cont. on next page

the air stream and make it bend inwards into the premises (when the premises are heated and the outdoor air is cold).

The air stream should therefore be directed outwards to withstand the load. Generally speaking, the higher the load, the greater the angle that is needed.

Basic setting of fan speed

The fan speed when the door is open is set using the speed control. Note that the air flow direction and speed may need fine adjustment depending on the loading of the door.

Filter (W)

The heating coil is protected by an air filter which covers the coil face.

Service, repairs and maintenance

For all service, repair and maintenance first carry out the following:

1. Disconnect the power supply.
2. The base plate/service hatch is opened by loosening the snap fixings located on the down side (turn 90°) and then loosening the base plate from the rim. See fig. 3 and 4.
3. After service, repair and maintenance close the base plate/service hatch and make sure that the snap fixings lock properly.

Maintenance

The appliance filter should be cleaned regularly to ensure the air curtain effect and the heat emission from the device. How often depends on local circumstances. A clogged filter is not a risk, but the appliance function can fail.

- 1 Disconnect the power.
2. The base plate/service hatch is opened by loosening the snap fixings located on the down side (turn 90°) and then loosening the base plate from the rim. See fig. 3 and 4.
- 3 Remove the filter and vacuum clean or wash it. If the filter is clogged, it may need to be changed.

Since fan motors and other components are maintenance free, no maintenance other than regular cleaning is necessary. The frequency of cleaning can vary depending on local conditions, but undertake cleaning at least twice a year. Inlet and exhaust grilles, impeller and elements can be vacuum cleaned or wiped using a dry cloth. Use a brush when vacuuming to prevent damaging sensitive parts. Avoid the use of strong alkaline or acidic cleaning agents.

Overheating

The air curtain unit with electric heater is equipped with an overheat protector. If this is deployed due to overheating, reset as follows:

1. Disconnect the electricity using the omnipolar switch.
2. Allow the electrical coil to cool.
3. Determine the cause of overheating and rectify the fault.

Reset is performed as follows:

1. Locate the red button inside the air curtain unit. This is visible and accessible by opening the base plate. The button is located outside the connection box. On the 2-metre variant, a red button is located outside each connection space.
2. Press the red button until a click is heard.
3. Connect the air curtain again.

The motors in all the air curtain units have a built-in thermal safety cut-out to protect against overheating. This will reset automatically once the motor has cooled.

cont. on next page

Fan replacement

1. Determine which of the fans is not functioning.
2. Disconnect the cables to the relevant fan.
3. Remove the screws securing the fan and lift the fan out.
4. Install the new fan in reverse order to the above.

Changing the electric coil/battery (E)

1. Mark and disconnect the cables to the electric coil/battery.
2. Remove the mounting screws securing the electric coil/battery in the unit and lift the electric coil/battery out.
3. Install the new electric coil/battery in reverse order to the above.

Replacing the electric heater/coil (E)

1. Mark and disconnect the cables to the electric heater/coil.
2. Remove the mounting screws securing the electric heater/coil in the unit and lift the electric heater/coil out.
3. Install the new electric heater/coil in reverse order to the above.

Trouble shooting

If the fans are not working or do not blow properly, check the following:

- Operating power supply to the unit; check fuses, circuit-breaker, time switch/thermostat (if any) that starts and stops the unit.
- That the air flow selector is correctly set.
- That the position limit switch is working.
- That the overheat protection for the motors has not been deployed.
- That the intake grille is not dirty.

If there is no heat, check the following:

- That the heat demand exists; check thermostat settings and actual temperature.

For units with electrical heating, check the following:

- Power supply to electric heater coil; check fuses and circuit-breaker (if any).
- That the overheat protection for the motors has not been deployed.

For units with water coil, check the following:

- That the water coil is air free.
- That there is enough water flow.
- That incoming water is heated enough.

If the fault cannot be rectified, please contact a qualified service technician.

Residual current circuit breaker (E)

When the installation is protected by means of a residual current circuit breaker, which trips when the appliance is connected, this may be due to moisture in the heating element. When an appliance containing a heater element has not been used for a long period or stored in a damp environment, moisture can enter the element.

This should not be seen as a fault, but is simply rectified by connecting the appliance to the mains supply via a

socket without a safety cut-out, so that the moisture can be eliminated from the element. The drying time can vary from a few hours to a few days. As a preventive measure, the unit should occasionally be run for a short time when it is not being used for extended periods of time.

Safety

- *For all installations of electrically heated products should a residual current circuit breaker 300 mA for fire protection be used.*
- *Keep the areas around the air intake and exhaust grilles free from possible obstructions!*
- *During operation the surfaces of the unit can be hot!*
- *The unit must not be fully or partially covered with clothing, or similar materials, as overheating can result in a fire risk! (E)*
- *This appliance is not intended for use by persons (including children) with reduced physical or mental capabilities, or lack of experience and knowledge, unless they have been given supervision or instruction concerning use of the appliance by a person responsible for their safety. Children should be supervised to ensure that they do not play with the appliance.*

Technical data is shown on p. 17.

Main office

Frico AB
Box 102
SE-433 22 Partille
Sweden

Tel: +46 31 336 86 00
Fax: +46 31 26 28 25
mailbox@frico.se
www.frico.se

**For latest updated information and information
about your local contact: www.frico.se**